

# Lanner

## Embedded Computing Platform

Hardware Platforms for Intelligent Edge Computing

# EAI-I251 User Manual

Version: 1.2

Date of Release: 2025-09-30

## About this Document



This manual describes the overview of the various functionalities of this product, and the information you need to get it ready for operation. It is intended for those who are:

- responsible for installing, administering and troubleshooting this system or Information Technology professionals.
- assumed to be qualified in the servicing of computer equipment, such as professional system integrators, or service personnel and technicians.

The latest version of this document can be found on Lanner’s official website, available either through the product page or through the [Lanner Download Center](#) page with a login account and password.

## Conventions & Icons

The icons are used in the manual to serve as an indication of interest topics or important messages.

| Icon  | Usage  |
|---|--|
|  <b>Note or Information</b>  | This mark indicates that there is something you should pay special attention to while using the product.               |
|  <b>Warning or Important</b> | This mark indicates that there is a caution or warning and it is something that could damage your property or product. |

## Online Resources

To obtain additional documentation resources and software updates for your system, please visit the [Lanner Download Center](#). As certain categories of documents are only available to users who are logged in, please be registered for a Lanner Account at <http://www.lannerinc.com/> to access published documents and downloadable resources.

## Technical Support

In addition to contacting your distributor or sales representative, you could submit a request at our [Lanner Technical Support](#) and fill in a support ticket to our technical support department.

## Documentation Feedback

Your feedback is valuable to us, as it will help us continue to provide you with more accurate and relevant documentation. To provide any feedback, comments or to report an error, please email [contact@lannerinc.com](mailto:contact@lannerinc.com). Thank you for your time.

## Contact Information

### Taiwan Corporate Headquarters

**Lanner Electronics Inc.**

7F, No.173, Sec.2, Datong Rd.  
Xizhi District, New Taipei City 22184,  
Taiwan

**立端科技股份有限公司**

221 新北市汐止區  
大同路二段 173 號 7 樓

T: +886-2-8692-6060

F: +886-2-8692-6101

E: [contact@lannerinc.com](mailto:contact@lannerinc.com)

### USA

**Lanner Electronics Inc.**

47790 Westinghouse Drive  
Fremont, CA 94539

T: +1-855-852-6637

F: +1-510-979-0689

E: [sales\\_us@lannerinc.com](mailto:sales_us@lannerinc.com)

### Europe

**Lanner Europe B.V.**

Wilhelmina van Pruisenweg 104  
2595 AN The Hague  
The Netherlands

T: +31 70 701 3256

E: [sales\\_eu@lannerinc.com](mailto:sales_eu@lannerinc.com)

### China

**Beijing L&S Lancom Platform Tech. Co., Ltd.**

Guodong LOFT 9 Layer No. 9 Huinan Road,  
Huilongguan Town, Changping District, Beijing  
102208 China

T: +86 010-82795600

F: +86 010-62963250

E: [service@ls-china.com.cn](mailto:service@ls-china.com.cn)

### Canada

**Lanner Electronics Canada Ltd**

3160A Orlando Drive  
Mississauga, ON

L4V 1R5 Canada

T: +1 877-813-2132

F: +1 905-362-2369

E: [sales\\_ca@lannerinc.com](mailto:sales_ca@lannerinc.com)

## Copyright and Trademarks

This document is copyrighted © 2025 by Lanner Electronics Inc. All rights are reserved. The original manufacturer reserves the right to make improvements to the products described in this manual at any time without notice. No part of this manual may be reproduced, copied, translated or transmitted in any form or by any means without the prior written permission of the original manufacturer. Information provided in this manual is intended to be accurate and reliable. However, the original manufacturer assumes no responsibility for its use, nor for any infringements upon the rights of third parties that may result from such use.

## Acknowledgment

Intel® and Intel® Atom® are trademarks of Intel Corporation or its subsidiaries in the U.S. and/or other countries. Microsoft Windows and MS-DOS are registered trademarks of Microsoft Corp. All other product names or trademarks are properties of their respective owners.

## Federal Communication Commission Interference Statement

This equipment has been tested and found to comply with the limits for a Class A digital device, pursuant to Part 15 of FCC Rules. These limits are designed to provide reasonable protection against harmful interference in a residential installation. This equipment generates, uses and can radiate radio frequency energy and, if not installed and used in accordance with the instruction, may cause harmful interference to radio communications. However, there is no guarantee that interference will not occur in a particular installation. If this equipment does cause harmful interference to radio or television reception, which can be determined by turning the equipment off and on, the user is encouraged to try to correct the interference by one or more of the following measures:

- ▶ Reorient or relocate the receiving antenna.
- ▶ Increase the separation between the equipment and receiver.
- ▶ Connect the equipment into an outlet on a circuit different from that to which the receiver is connected.
- ▶ Consult the dealer or an experienced radio/TV technician for help.

### FCC Caution

- ▶ Any changes or modifications not expressly approved by the party responsible for compliance could void the user's authority to operate this equipment.
- ▶ This transmitter must not be co-located or operating in conjunction with any other antenna or transmitter.



### Note

1. An unshielded-type power cord is required to meet FCC emission limits and to prevent interference to the nearby radio and television reception. It is essential that only the supplied power cord be used.
2. Use only shielded cables to connect I/O devices to this equipment.
3. Changes or modifications not expressly approved by the party responsible for compliance could void the user's authority to operate the equipment.



### Important

1. Operations in the 5.15-5.25GHz band are restricted to indoor usage only.
2. This device meets all the other requirements specified in Part 15E, Section 15.407 of the FCC Rules.

## Safety Guidelines

Follow these guidelines to ensure general safety:

- ▶ Keep the chassis area clear and dust-free during and after installation.
- ▶ Do not wear loose clothing or jewelry that could get caught in the chassis. Fasten your tie or scarf and roll up your sleeves.
- ▶ Wear safety glasses if you are working under any conditions that might be hazardous to your eyes.
- ▶ Do not perform any action that creates a potential hazard to people or makes the equipment unsafe.
- ▶ Disconnect all power by turning off the power and unplugging the power cord before installing or removing a chassis or working near power supplies
- ▶ Do not work alone if potentially hazardous conditions exist.
- ▶ Never assume that power is disconnected from a circuit; always check the circuit.

## Consignes de sécurité

Suivez ces consignes pour assurer la sécurité générale :

- ▶ Laissez la zone du châssis propre et sans poussière pendant et après l'installation.
- ▶ Ne portez pas de vêtements amples ou de bijoux qui pourraient être pris dans le châssis. Attachez votre cravate ou écharpe et remontez vos manches.
- ▶ Portez des lunettes de sécurité pour protéger vos yeux.
- ▶ N'effectuez aucune action qui pourrait créer un danger pour d'autres ou rendre l'équipement dangereux.
- ▶ Coupez complètement l'alimentation en éteignant l'alimentation et en débranchant le cordon d'alimentation avant d'installer ou de retirer un châssis ou de travailler à proximité de sources d'alimentation.
- ▶ Ne travaillez pas seul si des conditions dangereuses sont présentes.
- ▶ Ne considérez jamais que l'alimentation est coupée d'un circuit, vérifiez toujours le circuit. Cet appareil génère, utilise et émet une énergie radiofréquence et, s'il n'est pas installé et utilisé conformément aux instructions des fournisseurs de composants sans fil, il risque de provoquer des interférences dans les communications radio.

## Lithium Battery Caution

- ▶ There is risk of Explosion if Battery is replaced by an incorrect type.
- ▶ Dispose of used batteries according to the instructions.
- ▶ Installation only by a skilled person who knows all Installation and Device Specifications which are to be applied.
- ▶ Do not carry the handle of power supplies when moving to another place.
- ▶ Please conform to your local laws and regulations regarding safe disposal of lithium BATTERY.
- ▶ Disposal of a battery into fire or a hot oven, or mechanically crushing or cutting of a battery can result in an explosion.
- ▶ Leaving a battery in an extremely high temperature surrounding environment can result in an explosion or the leakage of flammable liquid or gas.
- ▶ A battery subjected to extremely low air pressure that may result in an explosion or the leakage of flammable liquid or gas.

## Avertissement concernant la pile au lithium

- ▶ Risque d'explosion si la pile est remplacée par une autre d'un mauvais type.
- ▶ Jetez les piles usagées conformément aux instructions.
- ▶ L'installation doit être effectuée par un électricien formé ou une personne formée à l'électricité connaissant toutes les spécifications d'installation et d'appareil du produit.
- ▶ Ne transportez pas l'unité en la tenant par le câble d'alimentation lorsque vous déplacez l'appareil.

## Operating Safety

- ▶ Electrical equipment generates heat. Ambient air temperature may not be adequate to cool equipment to acceptable operating temperatures without adequate circulation. Be sure that the room in which you choose to operate your system has adequate air circulation.
- ▶ Ensure that the chassis cover is secure. The chassis design allows cooling air to circulate effectively. An open chassis permits air leaks, which may interrupt and redirect the flow of cooling air from internal components.
- ▶ Electrostatic discharge (ESD) can damage equipment and impair electrical circuitry. ESD damage occurs when electronic components are improperly handled and can result in complete or intermittent failures. Be sure to follow ESD-prevention procedures when removing and replacing components to avoid these problems.
- ▶ Wear an ESD-preventive wrist strap, ensuring that it makes good skin contact. If no wrist strap is available, ground yourself by touching the metal part of the chassis.

- ▶ Periodically check the resistance value of the antistatic strap, which should be between 1 and 10 megohms (Mohms).

## Sécurité de fonctionnement

- ▶ L'équipement électrique génère de la chaleur. La température ambiante peut ne pas être adéquate pour refroidir l'équipement à une température de fonctionnement acceptable sans circulation adaptée. Vérifiez que votre site propose une circulation d'air adéquate.
- ▶ Vérifiez que le couvercle du châssis est bien fixé. La conception du châssis permet à l'air de refroidissement de bien circuler. Un châssis ouvert laisse l'air s'échapper, ce qui peut interrompre et rediriger le flux d'air frais destiné aux composants internes.
- ▶ Les décharges électrostatiques (ESD) peuvent endommager l'équipement et gêner les circuits électriques. Des dégâts d'ESD surviennent lorsque des composants électroniques sont mal manipulés et peuvent causer des pannes totales ou intermittentes. Suivez les procédures de prévention d'ESD lors du retrait et du remplacement de composants.
- ▶ Portez un bracelet anti-ESD et veillez à ce qu'il soit bien au contact de la peau. Si aucun bracelet n'est disponible, reliez votre corps à la terre en touchant la partie métallique du châssis.
- ▶ Vérifiez régulièrement la valeur de résistance du bracelet antistatique, qui doit être comprise entre 1 et 10 mégohms (Mohms).

### Mounting Installation Precaution

- ▶ Do not install and/or operate this unit in any place that flammable objects are stored or used in.
- ▶ If installed in a closed or multi-unit rack assembly, the operating ambient temperature of the rack environment may be greater than room ambient. Therefore, consideration should be given to installing the equipment in an environment compatible with the maximum ambient temperature (T<sub>ma</sub>) specified by the manufacturer.
- ▶ Installation of the equipment (especially in a rack) should consider the ventilation of the system's intake (for taking chilled air) and exhaust (for emitting hot air) openings so that the amount of airflow required for safe operation of the equipment is not compromised.
- ▶ To avoid a hazardous load condition, be sure the mechanical loading is even when mounting.
- ▶ Consideration should be given to the connection of the equipment to the supply circuit and the effect that overloading of the circuits might have on over-current protection and supply wiring. Appropriate consideration of equipment nameplate ratings should be used when addressing this concern.
- ▶ Reliable earthing should be maintained. Particular attention should be given to supply connections other than direct connections to the branch circuit (e.g., use of power strips).

### Installation & Operation:

- ▶ This equipment must be grounded. The power cord for product should be connected to a socket-outlet with earthing connection.  
Cet équipement doit être mis à la terre. La fiche d'alimentation doit être connectée à une prise de terre correctement câblée
- ▶ Suitable for installation in Information Technology Rooms in accordance with Article 645 of the National Electrical Code and NFPA 75.  
Peut être installé dans des salles de matériel de traitement de l'information conformément à l'article 645 du National Electrical Code et à la NFPA 75.
- ▶ The machine can only be used in a restricted access location and must be installed by a skilled person.  
Les matériels sont destinés à être installés dans des EMPLACEMENTS À ACCÈS RESTREINT.

### Warning

- ▶ Class I Equipment. This equipment must be earthed. The power plug must be connected to a properly wired earth ground socket outlet. An improperly wired socket outlet could place hazardous voltages on accessible metal parts.
- ▶ Product shall be used with Class 1 laser device modules.

### Avertissement

- ▶ Équipement de classe I. Ce matériel doit être relié à la terre. La fiche d'alimentation doit être raccordée à une prise de terre correctement câblée. Une prise de courant mal câblée pourrait induire des tensions dangereuses sur des parties métalliques accessibles.
- ▶ Le produit doit être utilisé avec des modules de dispositifs laser de classe 1.

## Electrical Safety Instructions

Before turning on the device, ground the grounding cable of the equipment. Proper grounding (grounding) is very important to protect the equipment against the harmful effects of external noise and to reduce the risk of electrocution in the event of a lightning strike. To uninstall the equipment, disconnect the ground wire after turning off the power. A ground wire is required and the part connecting the conductor must be greater than 4 mm<sup>2</sup> or 10 AWG.

## Consignes de sécurité électrique

- ▶ Avant d'allumer l'appareil, reliez le câble de mise à la terre de l'équipement à la terre.
- ▶ Une bonne mise à la terre (connexion à la terre) est très importante pour protéger l'équipement contre les effets néfastes du bruit externe et réduire les risques d'électrocution en cas de foudre.
- ▶ Pour désinstaller l'équipement, débranchez le câble de mise à la terre après avoir éteint l'appareil.
- ▶ Un câble de mise à la terre est requis et la zone reliant les sections du conducteur doit faire plus de 4 mm<sup>2</sup> ou 10 AWG.

# Table of Contents

---

|   |           |
|---|-----------|
| <b>Chapter 1: Product Overview .....</b>            | <b>9</b>  |
| Ordering Information .....                          | 9         |
| Optional Accessories .....                          | 9         |
| System Specifications .....                         | 10        |
| Front Panel .....                                   | 11        |
| Rear Panel .....                                    | 12        |
| Side Panel .....                                    | 13        |
| <b>Chapter 2: Motherboard Information .....</b>     | <b>14</b> |
| Internal Jumpers and Connector .....                | 15        |
| <b>Chapter 3: Hardware Setup .....</b>              | <b>23</b> |
| Opening the Chassis .....                           | 23        |
| Installing Storage Module Card (Optional) .....     | 24        |
| Installing Wi-Fi Module Card (Optional) .....       | 25        |
| Installing LTE/5G Module Card (Optional) .....      | 27        |
| Installing Nano SIM Card (Optional).....            | 31        |
| Wall Mounting.....                                  | 32        |
| VESA Mount (Optional) .....                         | 33        |
| <b>Appendix A: LED Indicator Explanations .....</b> | <b>34</b> |
| <b>Appendix B: Terms and Conditions .....</b>       | <b>36</b> |
| Warranty Policy .....                               | 36        |

# CHAPTER 1: PRODUCT OVERVIEW

The EAI-I251, powered by the NVIDIA Jetson Orin™ family with up to 2,048 CUDA cores and 64 Tensor Cores, delivers 248 TOPS AI performances. Built for extreme environments (-40°C to 70°C), it enables low-latency AI at the edge for traffic monitoring, factory inspection, and security. With GMSL2 video-in, 10G LAN (PoE+), USB 3.2, COM, DIO, Wi-Fi, and 5G, it ensures seamless integration for mission-critical AI applications.

## Package Content

Your package contains the following items:

- ▶ 1x EAI-I251 AI Inference System
- ▶ 1x Terminal Block (DIO/PWR)



**Note:** If you should find any components missing or damaged, please contact your dealer immediately for assistance.

## Ordering Information

| SKU       | CPU                           | Memory                  | Storage   | LAN & I/O  | Power      |
|-----------|-------------------------------|-------------------------|---|--|------------|
| EAI-I251A | NVIDIA®<br>Jetson<br>AGX Orin | LPDDR5<br>DRAM,<br>64GB | Onboard eMMC 5.1, 64GB;<br>1x M.2 2280 M-Key<br>(NVMe Default 128G) | 1x GbE RJ45;<br>1x 10GbE RJ45;<br>2x 2.5GbE RJ45 w/ PoE+;<br>2x COM (Optional CAN);<br>4x USB 3.2;<br>1x HDMI;<br>8x GMSL2 | DC 12V/24V |

## Optional Accessories

| Model             | Description                                     |
|-------------------|---|
| LTE Antenna Kit   | EAI-I251 LTE Antenna Kit without LTE Module     |
| Wi-Fi Antenna Kit | EAI-I251 WI-FI Antenna Kit without WI-FI Module |
| VESA Mount Kit    | VESA Rotate DIN Rail Kit                        |

## System Specifications

|                          |                       |  |
|--------------------------|-----------------------|--|
| <b>Processor System</b>  | SOM                   | NVIDIA® Jetson AGX Orin, 64GB  |
|                          | CPU                   | NVIDIA Arm® Cortex A78AE, 12-Core                                      |
|                          | GPU                   | NVIDIA Ampere, 2048 CUDA Cores, 64 Tensor Cores, 1.185MHz              |
| <b>Memory</b>            | Technology            | LPDDR5 DRAM with ECC   |
|                          | Max. Capacity         | 64GB   |
| <b>Ethernet</b>          | Interface             | 1x GbE Rj45;<br>1x 10GbE RJ45;<br>2x 2.5GbE RJ45 with PoE+             |
|                          | Speed                 | 10/100/1000/2500/5000/10000 Mbps                                       |
| <b>I/O</b>               | Reset Button          | 1x Reset Button  |
|                          | Serial Port           | 2x DB9 RS232/422/485 (2x CAN Optional) Ports                           |
|                          | Display Port          | 1x HDMI Port   |
|                          | USB Port              | 4x USB 3.2 Type A Ports  |
|                          | Digital I/O           | 4x DI (Support PNP / NPN / Dry Contact);<br>2x DO (Support Dry / Sink) |
|                          | Audio                 | 1x Line-In; 1x Line-Out  |
|                          | Video-In              | 8x GMSL2 (Gigabit Multimedia Serial Link) Deserializer                 |
| <b>Storage</b>           | Antenna               | 4x Antenna for LTE/5G Sub 6;<br>2x Antenna for Wi-Fi                   |
|                          | eMMC                  | Onboard eMMC 5.1, 64GB   |
| <b>Expansion</b>         | Onboard Slots         | 1x M.2 2280 M-Key for NVMe (Default 128G)                              |
|                          | M.2                   | 1x M.2 2230 E-Key for Wi-Fi<br>1x M.2 3042/3052 B-Key for LTE/5G       |
|                          | SIM Card              | 2x Nano-SIM (Support Dual SIM)   |
| <b>Miscellaneous</b>     | Watchdog              | Yes  |
|                          | Internal RTC          | Yes, with Li Battery   |
|                          | TPM                   | Onboard TPM 2.0  |
| <b>Cooling</b>           | Processor             | Passive Heatsink   |
|                          | System                | 1x 12V Fan, 120x120x25mm, 2200 RPM (1025 FAN)                          |
| <b>Environment</b>       | Operating Temperature | -40°C~70°C (35W)<br>-40°C~60°C (60W)                                   |
|                          | Storage Temperature   | -40°C to 80°C  |
|                          | Relative Humidity     | 5%~90% Operating;<br>5%~95% Non-Operating                              |
| <b>System Dimensions</b> | Dimensions (WxHxD)    | 201x 95 x 196 mm   |
|                          | Weight                | TBD  |
|                          | Mounting              | Wall Mount   |
| <b>Power</b>             | Type/Watts            | 12V/24V DC   |
|                          | Connector             | 1x 2-Pin Terminal Block  |
| <b>Driver Support</b>    | OS                    | Linux (NVIDIA Jetpack 6.2)   |
| <b>Certification</b>     | EMC                   | CE/UKCA, FCC Class A, RoHS   |
|                          | Safety                | MTBF, UL_CB(62368-1)   |

## Front Panel

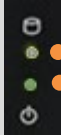

| No. | Description   |   |
|-----|---------------|---|
| F1  | Display Port  | 1x HDMI Port  |
| F2  | Video-In      | 8x GMSL2  |
| F3  | Audio Port    | 1x Line-in; 1x Line-out   |
| F4  | USB Port      | 4x USB 3.2 Type A Ports   |
| F5  | Power Button  | 1x Power On/Off Button  |
| F6  | LED Indicator |  <ul style="list-style-type: none"> <li><span style="color: green;">●</span> HDD Status</li> <li><span style="color: red;">●</span> System Power Status</li> </ul> |
| F7  | Reset Button  | 1x Reset Button   |

## Rear Panel



| No. | Power Input  |  |
|-----|--------------|--|
| R1  | Power Input  | 1x 2-pin Terminal Block, 12/24VDC  |
| R2  | LAN/PoE Port | LAN1: 1x 1GbE RJ45 Port;<br>LAN2/3: 2x 2.5GbE RJ45 w/ PoE+ (Total 30W) Port;<br>LAN4: 1x 10GbE RJ45 Port |
| R3  | DIO          | 1x 2x6-pin Terminal Block:<br>4x DI (Support PNP/NPN/Dry contact); 2x DO (Support Dry/Sink contact)      |
| R4  | COM/CAN Port | 2x DB9 RS232/422/485 (Optional for 2x CAN Port)  |

## Side Panel



| No. | Description |   |
|-----|-------------|---|
| S1  | SIM Cover   | SIM Cover w/ Intrusion Design for 2x Nano SIM; 1x Slide Switch for Recovery |
| S2  | Antenna     | 6x Antenna Holes for LTE/5G/Wi-Fi   |

# CHAPTER 2: MOTHERBOARD INFORMATION

## Block Diagram

The block diagram indicates how data flows among components on the motherboard.

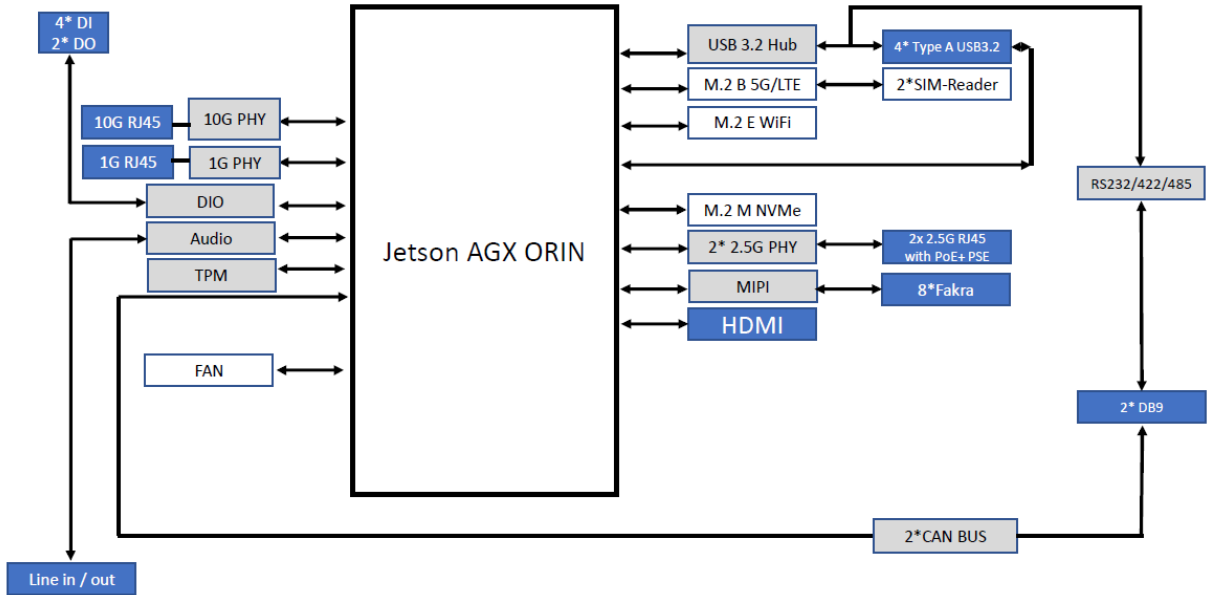

# Internal Jumpers and Connector

## Top Side of Main Board

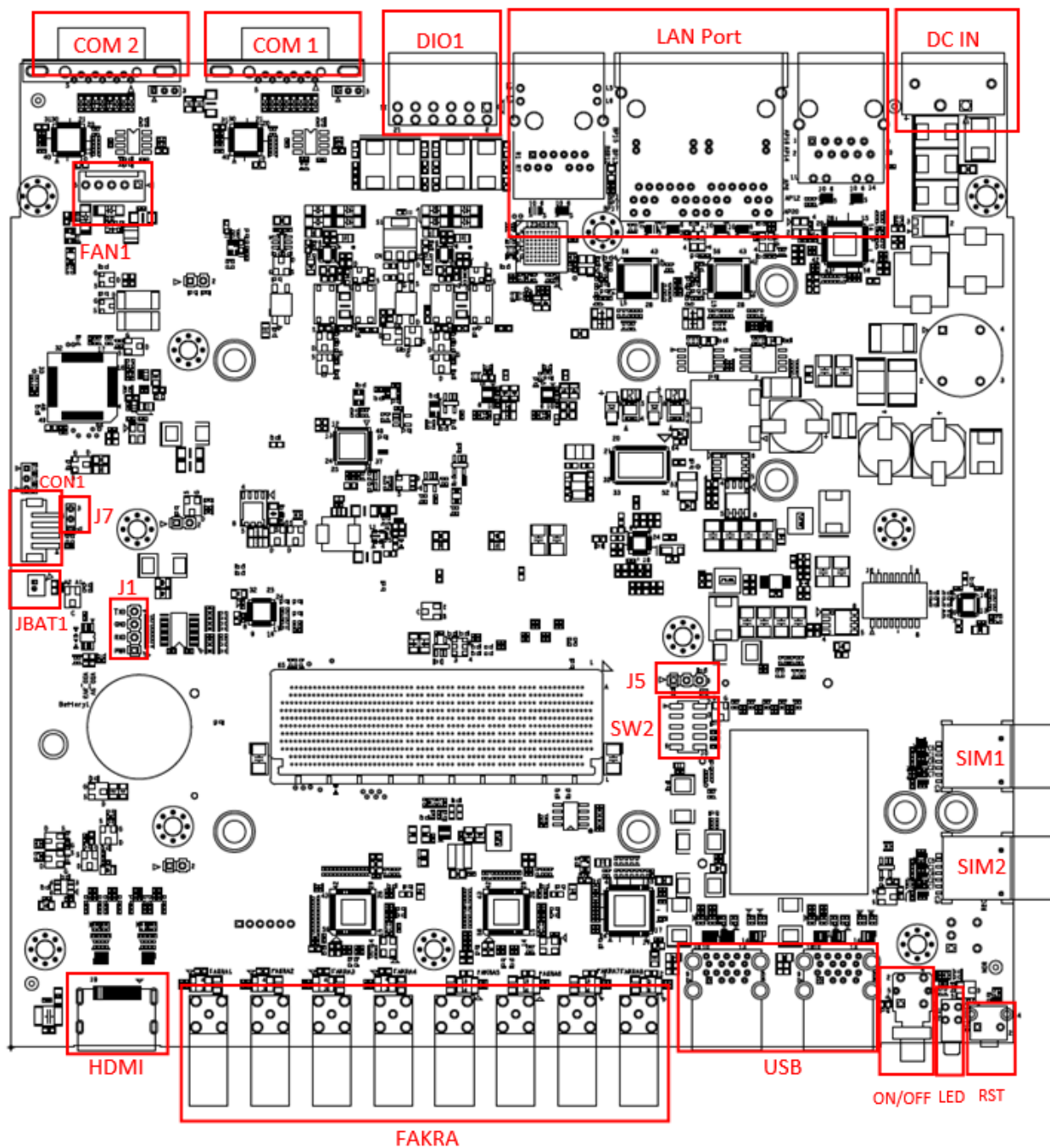

**Bottom Side of Main Board**

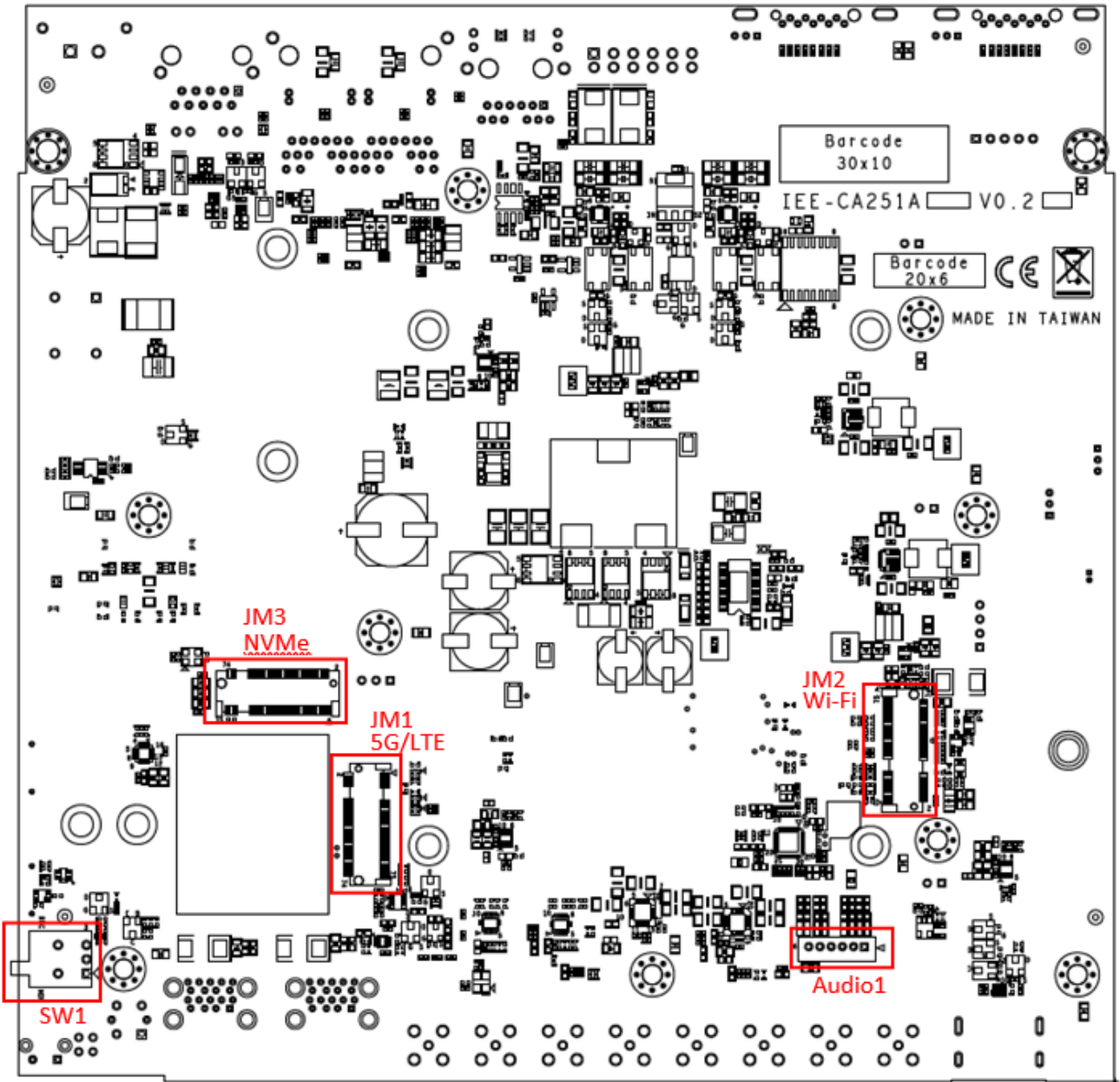

**J1: SOM Debug UART**

| PIN | Description     |
|-----|-----------------|
| 1   | UART3_PWR(3.3V) |
| 2   | UART3_RXD       |
| 3   | GND             |
| 4   | UART3_TXD       |

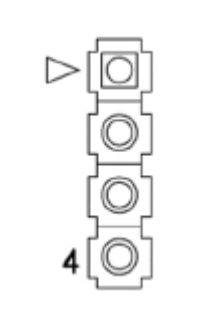

**J5: 5G NR PCIe Selector**

**(1-2) = USB I/F (Default)**

**(2-3) = PCIe I/F (Not Support)**

| PIN | Description               |
|-----|---------------------------|
| 1   | 10K pull up to P1V8_5G NR |
| 2   | 5G_PCIE_SEL               |
| 3   | GND                       |

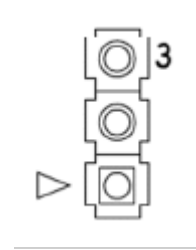

| Jumper | MV32-W | FN990 | EM9291 | RM520N |
|--------|--------|-------|--------|--------|
| 1-2    | N/A    | N/A   | Y      | N/A    |
| 3-4    | N/A    | N/A   | N/A    | N/A    |

**J7: MCU SIP Mode**

**(1-2) = Normal Operation (Default)**

**(2-3) = ISP Mode**

| PIN | Description              |
|-----|--------------------------|
| 1   | Pull up 10K to +P3V3_MCU |
| 2   | PIO0_12                  |
| 3   | GND                      |

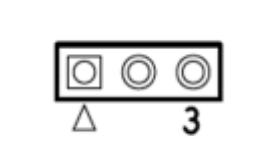

**JBAT1: RTC Battery Connector**

| PIN | Description |
|-----|-------------|
| 1   | VBAT        |
| 2   | GND         |

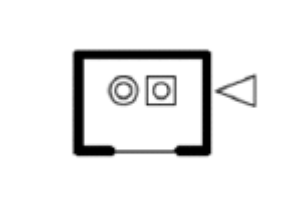

**FAN1: Fan Connector**

| PIN | Description |
|-----|-------------|
| 1   | GND         |
| 2   | P12V        |
| 3   | TACH1       |
| 4   | NA          |
| 5   | PWM         |

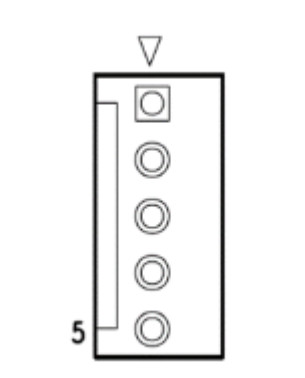

**SW1: Force Recovery (SOM FW Upgrade)**

**(1-2) = Normal Operation Mode (Default)**

**(2-3) = Force Recovery Mode**

| PIN | Description      |
|-----|------------------|
| 1   | NC               |
| 2   | FORCE_RECOVERY_N |
| 3   | GND              |

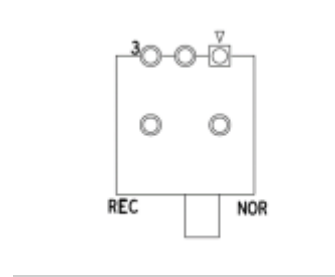

**SW2: Install Jumper (5G NR Module)**

| PIN | Description   |
|-----|---------------|
| 1   | NA            |
| 2   | NA            |
| 3   | 5G_VBUS_SENSE |
| 4   | 3.3V          |
| 5   | 5G_VCC1       |
| 6   | 3.3V          |
| 7   | 5G_VCC2       |
| 8   | 3.3V          |
| 9   | 5G_VCC3       |
| 10  | 3.3V          |

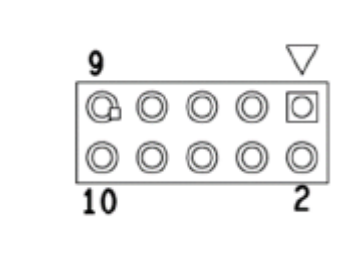

| Jumper     | MV32-W | FN990 | EM9291 | RM520N |
|------------|--------|-------|--------|--------|
| 3-4        | TBD    | N/A   | Active | TBD    |
| Remove 3-4 | TBD    | N/A   | N/A    | TBD    |

**JCON1: MCU FW Upgrade UART Port**

| PIN | Description |
|-----|-------------|
| 1   | +P3V3_MCU   |
| 2   | MCU_UART_RX |
| 3   | GND         |
| 4   | MCU_UART_TX |

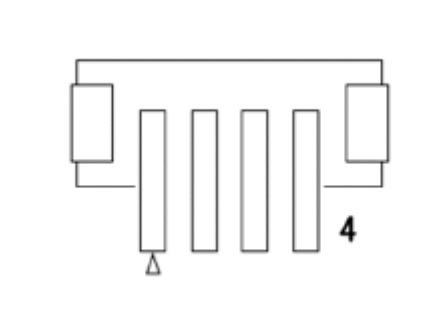

**COM1: COM Port 1**

| PIN | RS232 | RS422 | RS485 | CAN   |
|-----|-------|-------|-------|-------|
| 1   |       | TX-   | RTX-  |       |
| 2   | RXD   | TX+   | RTX+  |       |
| 3   | TXD   | RX+   |       |       |
| 4   |       | RX-   |       |       |
| 5   | GND   |       |       |       |
| 6   |       |       |       | CAN L |
| 7   | RTS   |       |       |       |
| 8   | CTS   |       |       |       |
| 9   |       |       |       | CAN H |



**COM2: COM Port 2**

| PIN | RS232 | RS422 | RS485 | CAN   |
|-----|-------|-------|-------|-------|
| 1   |       | TX-   | RTX-  |       |
| 2   | RXD   | TX+   | RTX+  |       |
| 3   | TXD   | RX+   |       |       |
| 4   |       | RX-   |       |       |
| 5   | GND   |       |       |       |
| 6   |       |       |       | CAN L |
| 7   | RTS   |       |       |       |
| 8   | CTS   |       |       |       |
| 9   |       |       |       | CAN H |



**DIO1: DI/DO Connector**

| Pin    | 7       | 8    | 9    | 10   | 11   | 12      |
|--------|---------|------|------|------|------|---------|
| Define | DI COM  | DI 1 | DI 2 | DI 3 | DI 4 | DIO GND |
| Pin    | 1       | 2    | 3    | 4    | 5    | 6       |
| Define | DIO GND | DO 1 | DO 2 | NC   | NC   | DIO GND |

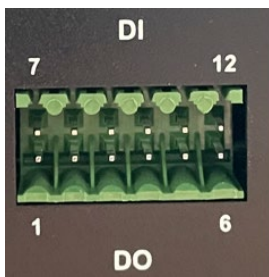

**Audio1: Audio Connector**

| PIN | Description |
|-----|-------------|
| 1   | LINE IN R   |
| 2   | LINE IN L   |
| 3   | GND_AUD     |
| 4   | GND_AUD     |
| 5   | LINE OUT R  |
| 6   | LINE OUT L  |



**JM1: M.2 B-Key Connector (For 5G Sub6 Module)**

| PIN | Description | PIN | Description        | PIN | Description    |
|-----|-------------|-----|--------------------|-----|----------------|
| 1   | NC          | 35  | PCIE_TXP           | 61  | M2E_AP_WAKE_BT |
| 2   | 3V3         | 36  | UART5_RTS          | 62  | M2E_ALERT_N    |
| 3   | USB2_D+     | 37  | PCIE_TXN           | 63  | GND            |
| 4   | 3V3         | 38  | NC                 | 64  | NC             |
| 5   | USB2_D-     | 39  | GND                | 65  | NC             |
| 6   | NC          | 40  | NC                 | 66  | NC             |
| 7   | GND         | 41  | PCIE_RXP           | 67  | NC             |
| 8   | NC          | 42  | M2E_AP_WAKE_BT     | 68  | NC             |
| 9   | NC          | 43  | PCIE_RXN           | 69  | GND            |
| 10  | NC          | 44  | NC                 | 70  | NC             |
| 11  | NC          | 45  | GND                | 71  | NC             |
| 12  | NC          | 46  | NC                 | 72  | 3V3            |
| 13  | NC          | 47  | PCIE_CLKP          | 73  | NC             |
| 14  | NC          | 48  | NC                 | 74  | 3V3            |
| 15  | NC          | 49  | PCIE_CLKN          | 75  | GND            |
| 16  | NC          | 50  | NC                 | 76  | NC             |
| 17  | NC          | 51  | GND                | 77  | NC             |
| 18  | GND         | 52  | PCIE_RESET_N       |     |                |
| 19  | NC          | 53  | PCIE_CLKREQ_N      |     |                |
| 20  | M2E_BT_WAKE | 54  | M2E_BT_DISABLE_N   |     |                |
| 21  | NC          | 55  | M2E_WIFI_WAKE      |     |                |
| 22  | UART5_RXD   | 56  | M2E_WIFI_DISABLE_N |     |                |
| 23  | GND         | 57  | GND                |     |                |
| 32  | UART5_TXD   | 58  | NC                 |     |                |
| 33  | GND         | 59  | M2E_SAR_TOUT       |     |                |
| 34  | UART5_CTS   | 60  | NC                 |     |                |

**JM2: M.2 E-Key Connector (For Wi-Fi Module)**

| PIN | Description | PIN | Description        | PIN | Description    |
|-----|-------------|-----|--------------------|-----|----------------|
| 1   | NC          | 35  | PCIE_TXP           | 61  | M2E_AP_WAKE_BT |
| 2   | 3V3         | 36  | UART5_RTS          | 62  | M2E_ALERT_N    |
| 3   | USB2_D+     | 37  | PCIE_TXN           | 63  | GND            |
| 4   | 3V3         | 38  | NC                 | 64  | NC             |
| 5   | USB2_D-     | 39  | GND                | 65  | NC             |
| 6   | NC          | 40  | NC                 | 66  | NC             |
| 7   | GND         | 41  | PCIE_RXP           | 67  | NC             |
| 8   | NC          | 42  | M2E_AP_WAKE_BT     | 68  | NC             |
| 9   | NC          | 43  | PCIE_RXN           | 69  | GND            |
| 10  | NC          | 44  | NC                 | 70  | NC             |
| 11  | NC          | 45  | GND                | 71  | NC             |
| 12  | NC          | 46  | NC                 | 72  | 3V3            |
| 13  | NC          | 47  | PCIE_CLKP          | 73  | NC             |
| 14  | NC          | 48  | NC                 | 74  | 3V3            |
| 15  | NC          | 49  | PCIE_CLKN          | 75  | GND            |
| 16  | NC          | 50  | NC                 | 76  | NC             |
| 17  | NC          | 51  | GND                | 77  | NC             |
| 18  | GND         | 52  | PCIE_RESET_N       |     |                |
| 19  | NC          | 53  | PCIE_CLKREQ_N      |     |                |
| 20  | M2E_BT_WAKE | 54  | ME_BT_DISABLE_N    |     |                |
| 21  | NC          | 55  | ME_WIFI_WAKE       |     |                |
| 22  | UART5_RXD   | 56  | M2E_WIFI_DISABLE_N |     |                |
| 23  | NC          | 57  | GND                |     |                |
| 32  | UART5_TXD   | 58  | NC                 |     |                |
| 33  | GND         | 59  | M2E_SAR_TOUT       |     |                |
| 34  | UART5_CTS   | 60  | NC                 |     |                |

**JM3: M.2 M-Key Connector (For NVMe SSD)**

| PIN | Description | PIN | Description | PIN | Description  |
|-----|-------------|-----|-------------|-----|--------------|
| 1   | GND         | 27  | GND         | 53  | PCIE_CLK_N   |
| 2   | 3V3         | 28  | NC          | 54  | PCIE_WAKE    |
| 3   | GND         | 29  | PCIE_RX1_N  | 55  | PCIE_CLK_P   |
| 4   | 3V3         | 30  | NC          | 56  | UFS0 REF CLK |
| 5   | PCIE_RX3_N  | 31  | PCIE_RX1_P  | 57  | GND          |
| 6   | NC          | 32  | NC          | 58  | UFS0 RST N   |

|    |               |    |               |    |     |
|----|---------------|----|---------------|----|-----|
| 7  | PCIE_RX3_P    | 33 | GND           | 67 | NC  |
| 8  | NC            | 34 | NC            | 68 | NC  |
| 9  | GND           | 35 | PCIE_TX1_M2_N | 69 | NC  |
| 10 | LED           | 36 | NC            | 70 | 3V3 |
| 11 | PCIE_TX3_M2_N | 37 | PCIE_TX1_M2_P | 71 | GND |
| 12 | 3V3           | 38 | NC            | 72 | 3V3 |
| 13 | PCIE_TX3_M2_P | 39 | GND           | 73 | GND |
| 14 | 3V3           | 40 | NC            | 74 | 3V3 |
| 15 | GND           | 41 | PCIE_RX0_N    | 75 | GND |
| 16 | 3V3           | 42 | NC            | 76 | NC  |
| 17 | PCIE_RX2_N    | 43 | PCIE_RX0_P    | 77 | NC  |
| 18 | 3V3           | 44 | ALERT_N       |    |     |
| 19 | PCIE_RX2_P    | 45 | GND           |    |     |
| 20 | NC            | 46 | NC            |    |     |
| 21 | GND           | 47 | PCIE_TX0_M2_N |    |     |
| 22 | NC            | 48 | NC            |    |     |
| 23 | PCIE_TX2_M2_N | 49 | PCIE_TX0_M2_P |    |     |
| 24 | NC            | 50 | PCIE_RST_R    |    |     |
| 25 | PCIE_TX2_M2_P | 51 | GND           |    |     |
| 26 | NC            | 52 | PCIE_CLK_REQ  |    |     |

## CHAPTER 3: HARDWARE SETUP

To reduce the risk of personal injury, electric shock, or damage to the unit, please remove all power connections to completely shut down the device, and wear ESD protection gloves when handling the installation steps.

### Opening the Chassis

1. Power off the system and disconnect the power cord. Turn the system over. Unscrew the six (6) screws on the bottom chassis cover, and two (2) screws on each side.



2. Lift and open the chassis.



## Installing Storage Module Card (Optional)

The system supports one M.2 M-Key module card for additional storage. Please follow the steps for installation.

1. Power off the system, turn the system around, and open the bottom chassis cover.
2. Locate the M.2 M-Key slot on the motherboard.



3. Next, thermal pad placement. Remove the protective film on the Thermal Pad (included in accessory pack) and gently place on the motherboard. The thermal pad needs to be placed underneath the module card.
4. Align the notch of the M.2 storage module card with the socket key in the pin slot.

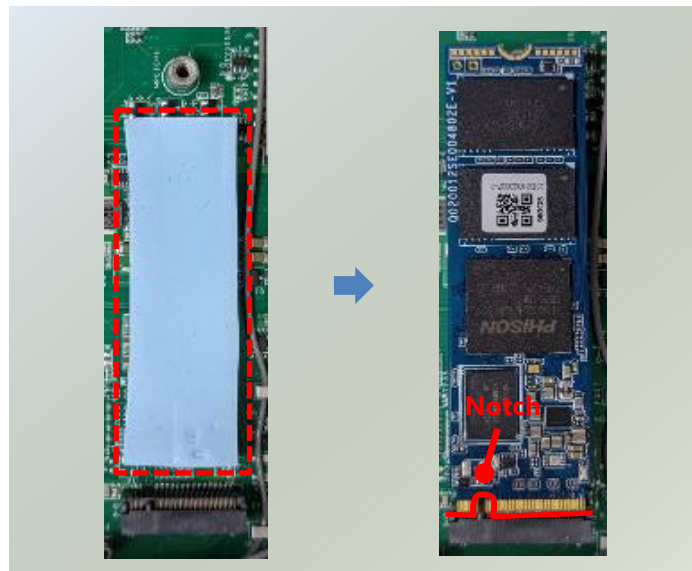

5. Insert the M.2 module card pins at 30 degrees into the socket until it is fully seated.
6. Push down on the module card and secure it with one screw.
7. Lastly, gently place another Thermal Pad over the module card.

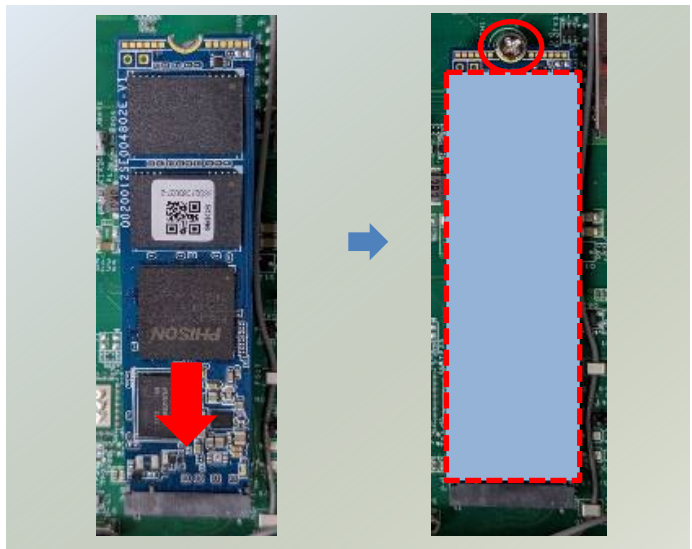

## Installing Wi-Fi Module Card (Optional)

The system supports one M.2 E-Key slot for a Wi-Fi module card, an optional accessory. Wi-Fi module requires two antennas. Please follow the steps to install the Wi-Fi module card.

1. Power off the system, turn the system around, and open the bottom chassis cover.
2. Locate the M.2 E-Key slot on the motherboard.



3. Next, thermal pad placement. Remove the protective film on the thermal pad (included in accessory pack) and gently place on the motherboard. The thermal pad needs to be underneath the module card.

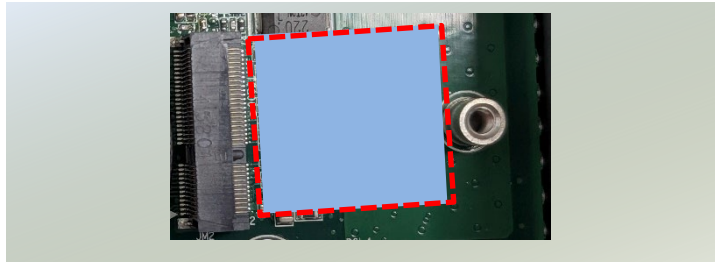

3. Align the notch of the Wi-Fi module card with the socket key in the pin slot.
4. Insert the Wi-Fi module card pins at 30 degrees into the socket until it is fully seated.

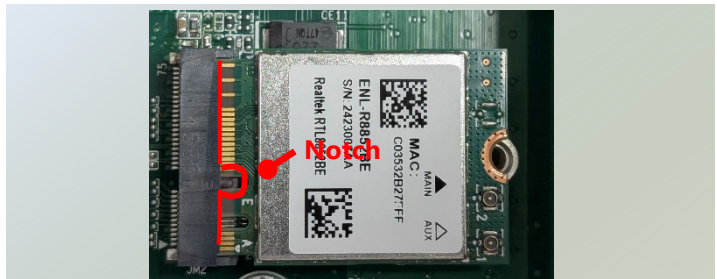

5. Push down on the module card and secure it with one screw.



## Installing Wi-Fi Antennas Right & Left Side Panels



1. Locate the two (2) antenna locations (A1, A2).  
Locate the two (2) IPEX connectors on the Wi-Fi module card.



2. Connect the RF cables to the Wi-Fi module card.



3. Screw on the two (2) antennas on the outside of the system.

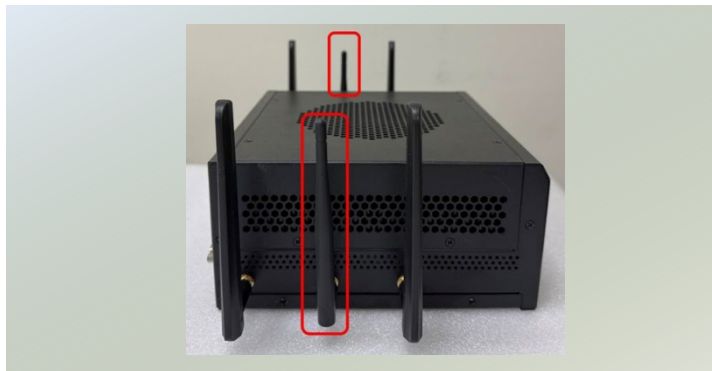

## Installing LTE/5G Module Card (Optional)

This system features one M.2 B-Key slot for an LTE/5G module card, supporting a dual Nano-SIM design. LTE module will require two antennas. 5G module will require four antennas. Please follow the procedures for the installation of the 5G module card.

1. Power off the system, turn the system around, and open the bottom chassis cover.
2. Locate the M.2 B-Key slot on the motherboard.



3. Next, thermal pad placement. Remove the protective film on the thermal pad (included in accessory pack) and gently place on the motherboard. The thermal pad needs to be underneath the module card.

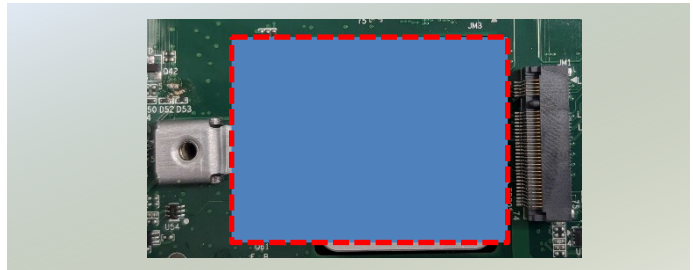

4. Align the notch of the LTE/5G module card with the socket key in the pin slot.
5. Insert the LTE/5G module card pins at 30 degrees into the socket until it is fully seated.

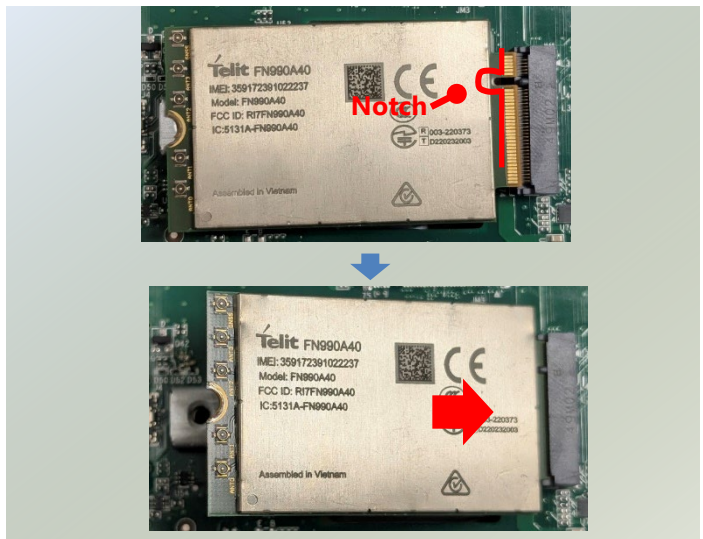

6. Push down on the module card and secure it with one screw.
7. Lastly, gently place a Thermal Pad over the module card.

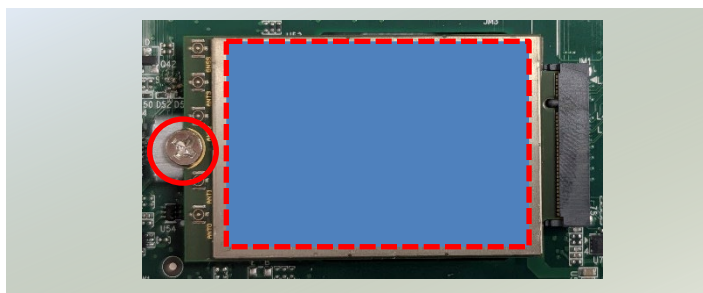

## Installing LTE Antennas Right & Left Side Panel



1. Locate the two (2) antenna locations (A1, A2).  
Locate the two (2) IPEX connectors on the LTE module card.

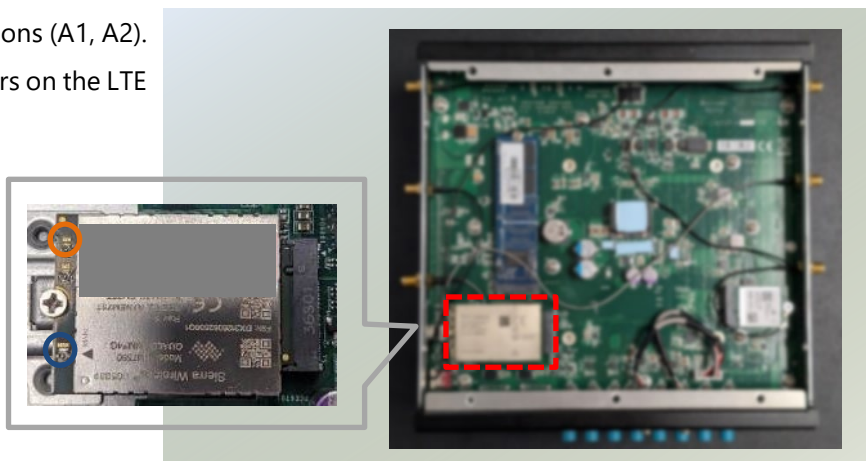

2. Connect the RF cables to the LTE module card.



3. Screw on the two (2) antennas on the outside of the system.



## Installing 5G Antennas Right & Left Side Panel



1. Locate the four (4) antenna locations (A1, A2, A3, A4). Locate the four (4) IPEX connectors on the 5G module card.

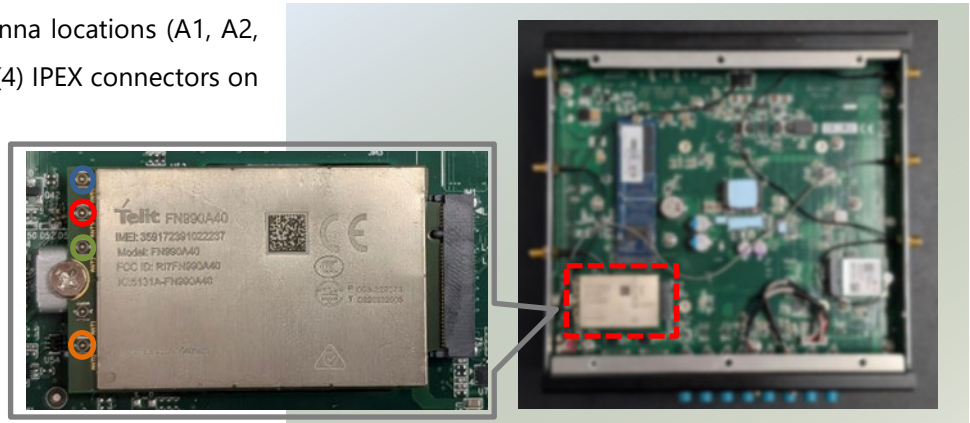

2. Connect the RF cables to the 5G module card.



3. Screw on the four (4) antennas to the outside of the system.

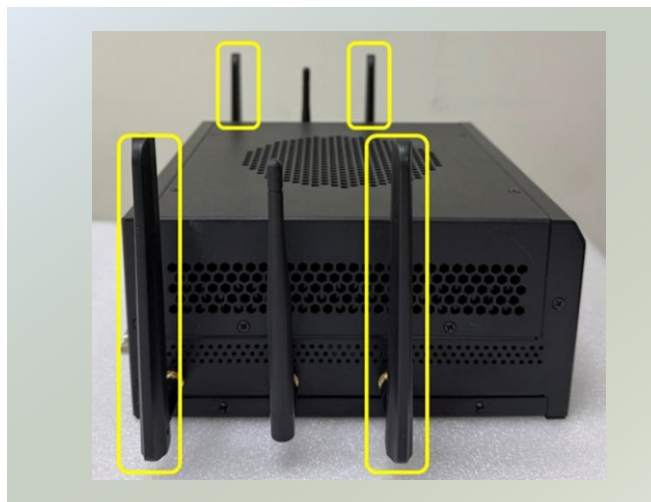

## Installing Nano SIM Card (Optional)

The SIM slot on the front panel supports 2x Nano SIM cards. The SIM socket supports the push-push mechanism, allowing inserting and ejecting the SIM card to be as easy as one push.

1. Locate the SIM card cover on the Right side panel.
2. Loosen and unscrew the one screw on the SIM card cover and remove the cover.



3. Two Nano SIM cards can be placed on the top layer. Insert and push the SIM card, gold contacts facing downwards, all the way in until it clicks into place. Repeat if placing two SIM cards.

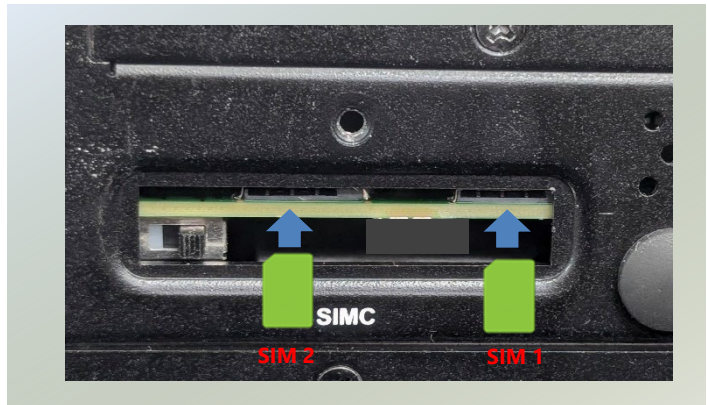

4. To remove the SIM card, use your fingertips to push it once, to have the card automatically eject.
5. Place the cover back and secure with one screw.

## Recovery Slide Switch

The SIMC cover also has 1x Slide Switch for Recovery. (Left: Normal Mode: Right: Recovery Mode)

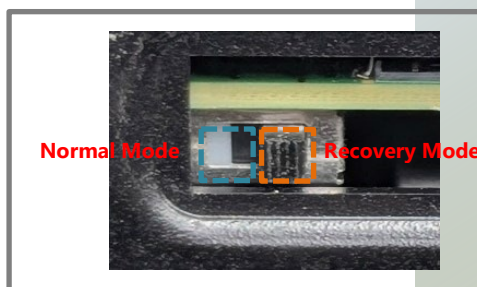

## Wall Mounting

The system can be mounted on a flat surfaced wall. Please take the following into considerations when mounting the system onto the wall.

1. The Wallmount Kit includes:

- ▶ 1x pair of Wall Brackets
- ▶ 1x Screw Pack



2. Invert the system to expose the bottom side. Secure the two all brackets to the system using six (6) screws, three (3) per bracket.



3. Now the system can be mounted on a flat surface wall.



### Note

- Installation must be performed by qualified personnel or subcontractors.
- Mounting is recommended on concrete walls.
- For all weight categories, use anti-loosening measures (spring washers, thread locker).
- In industrial environments (vibration, high temperature, outdoor), also apply anti-vibration pads and anti-corrosion screws.
- After installation, periodically inspect mounting points and screw tightness.
- Lanner assumes no liability for damage or injury resulting from mishandling or improper installation.

## VESA Mount (Optional)

A VESA (video electronics standards association) mount allows your system to be securely attached to a wall, monitor arm, or other mounting bracket, providing space efficiency, better ergonomics, and improved cable management. Please take the following into considerations when VESA mounting the system.

1. The VESA Mount Kit includes:

- ▶ 1x VESA Mount Bracket
- ▶ 1x Screw Pack

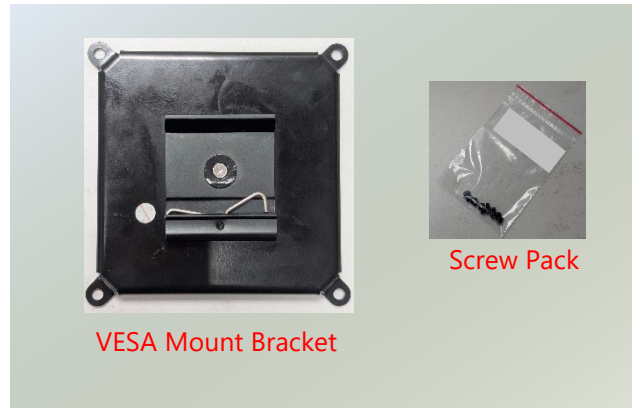

2. Invert the system to expose the bottom side. Secure the bracket to the system using four (4) screws.



3. Now the system can be securely attached to a wall, monitor arm, or other mounting brackets.

# APPENDIX A: LED INDICATOR EXPLANATIONS

► **System Power / Status / Storage / Activity**

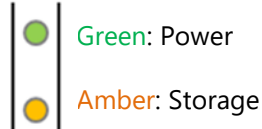

| LED     | Color | LED Action | Description   |
|---------|-------|------------|---|
| Power   | Green | Steady     | When system power ON                                  |
|         | Off   | N/A        | NO Power On   |
| Storage | Amber | Blinking   | Blinking indicates HDD activity (Include SATA / NVME) |
|         | Off   | N/A        | No data access or No Power On                         |

► **RJ-45 LAN LED**

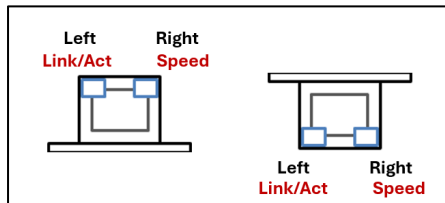

System View for RJ45 w/LED definition by Flat-Mount as Rack/Wall/Desk mount

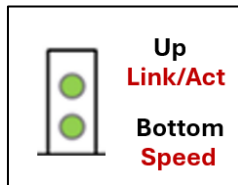

System View for RJ45 w/o LED definition by Flat-Mount as Rack/Wall/Desk mount

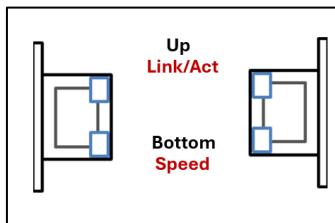

System View for RJ45 w/LED definition by DIN-rail / Vertical mount

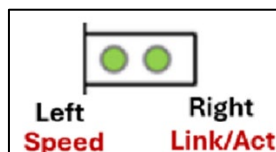

System View for RJ45 w/o LED definition by DIN-rail / Vertical mount

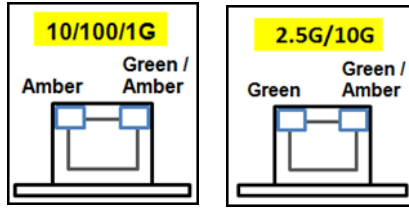

**1Gb RJ45 Define:**

| Speed       | Amber (Link/Active)         | Green / Amber (Link) |
|-------------|-----------------------------|----------------------|
| <b>10M</b>  | ON / Blinking (Data access) | OFF                  |
| <b>100M</b> | ON / Blinking (Data access) | ON (Green)           |
| <b>1G</b>   | ON / Blinking (Data access) | ON (Amber)           |

1. When cable is plug-in and network is linked. Both LED will be bright. The behavior is as defined.
2. Without the Cable plug-in, the LED should be off.
3. If LAN Driver controls the LED, the behavior will follow the driver.

**2.5Gb RJ45 Define:**

| Speed       | Green (Link/Active)         | Green / Amber (Link) |
|-------------|-----------------------------|----------------------|
| <b>100M</b> | ON / Blinking (Data access) | OFF                  |
| <b>1G</b>   | ON / Blinking (Data access) | ON (Amber)           |
| <b>2.5G</b> | ON / Blinking (Data access) | ON (Green)           |

1. When cable is plug-in and network is linked. Both LED will be bright. The behavior is as defined.
2. Without the Cable plug-in, the LED should be off.
3. If LAN Driver controls the LED, the behavior will follow the driver.

**10Gb RJ45 Define:**

| Speed           | Green (Link/Active)         | Green / Amber (Link) |
|-----------------|-----------------------------|----------------------|
| <b>100M</b>     | ON / Blinking (Data access) | OFF                  |
| <b>1/2.5/5G</b> | ON / Blinking (Data access) | ON (Amber)           |
| <b>10G</b>      | ON / Blinking (Data access) | ON (Green)           |

1. When cable is plug-in and network is linked. Both LED will be bright. The behavior is as defined.
2. Without the Cable plug-in, the LED should be off.
3. If LAN Driver controls the LED, the behavior will follow the driver.

# APPENDIX B: TERMS AND CONDITIONS

## Warranty Policy

1. All products are under warranty against defects in materials and workmanship for a period of one year from the date of purchase.
2. The buyer will bear the return freight charges for goods returned for repair within the warranty period; whereas the manufacturer will bear the after service freight charges for goods returned to the user.
3. The buyer will pay for the repair (for replaced components plus service time) and transportation charges (both ways) for items after the expiration of the warranty period.
4. If the RMA Service Request Form does not meet the stated requirement as listed on "RMA Service," RMA goods will be returned at customer's expense.
5. The following conditions are excluded from this warranty:
  - ▶ Improper or inadequate maintenance by the customer
  - ▶ Unauthorized modification, misuse, or reversed engineering of the product
  - ▶ Operation outside of the environmental specifications for the product.

## RMA Service

### Requesting an RMA#

1. To obtain an RMA number, simply fill out and fax the "RMA Request Form" to your supplier.
2. The customer is required to fill out the problem code as listed. If your problem is not among the codes listed, please write the symptom description in the remarks box.
3. Ship the defective unit(s) on freight prepaid terms. Use the original packing materials when possible.
4. Mark the RMA# clearly on the box.



**Note:** Customer is responsible for shipping damage(s) resulting from inadequate/loose packing of the defective unit(s). All RMA# are valid for 30 days only; RMA goods received after the effective RMA# period will be rejected.

## RMA Service Request Form

When requesting RMA service, please fill out the following form. Without this form enclosed, your RMA cannot be processed.

| <b>RMA No.:</b>  |            | Reasons to Return: <input type="checkbox"/> Repair(Please include failure details) |               |
|--|------------|--|---------------|
|  |            | <input type="checkbox"/> Testing Purpose   |               |
| Company:   |            | Contact Person:  |               |
| Phone No.  |            | Purchased Date:  |               |
| Fax No.:   |            | Applied Date:  |               |
| Return Shipping Address: _____   |            |  |               |
| Shipping by: <input type="checkbox"/> Air Freight <input type="checkbox"/> Sea <input type="checkbox"/> Express_____ |            |  |               |
| <input type="checkbox"/> Others:_____  |            |  |               |
|  |            |  |               |
| Item   | Model Name | Serial Number  | Configuration |
|  |            |  |               |
|  |            |  |               |
|  |            |  |               |
|  |            |  |               |
|  |            |  |               |
|  |            |  |               |
|  |            |  |               |
|  |            |  |               |

| Item | Problem Code | Failure Status |
|------|--------------|----------------|
|      |              |                |
|      |              |                |
|      |              |                |
|      |              |                |
|      |              |                |
|      |              |                |
|      |              |                |
|      |              |                |

- \*Problem Code:
- |                        |                              |                    |                          |
|------------------------|------------------------------|--------------------|--------------------------|
| 01: D.O.A.             | 07: BIOS Problem             | 13: SCSI           | 19: DIO                  |
| 02: Second Time R.M.A. | 08: Keyboard Controller Fail | 14: LPT Port       | 20: Buzzer               |
| 03: CMOS Data Lost     | 09: Cache RMA Problem        | 15: PS2            | 21: Shut Down            |
| 04: FDC Fail           | 10: Memory Socket Bad        | 16: LAN            | 22: Panel Fail           |
| 05: HDC Fail           | 11: Hang Up Software         | 17: COM Port       | 23: CRT Fail             |
| 06: Bad Slot           | 12: Out Look Damage          | 18: Watchdog Timer | 24: Others (Pls specify) |

***Request Party***

***Confirmed By Supplier***

\_\_\_\_\_  
**Authorized Signature / Date**

\_\_\_\_\_  
**Authorized Signature / Date**